

HL 188

HP 12

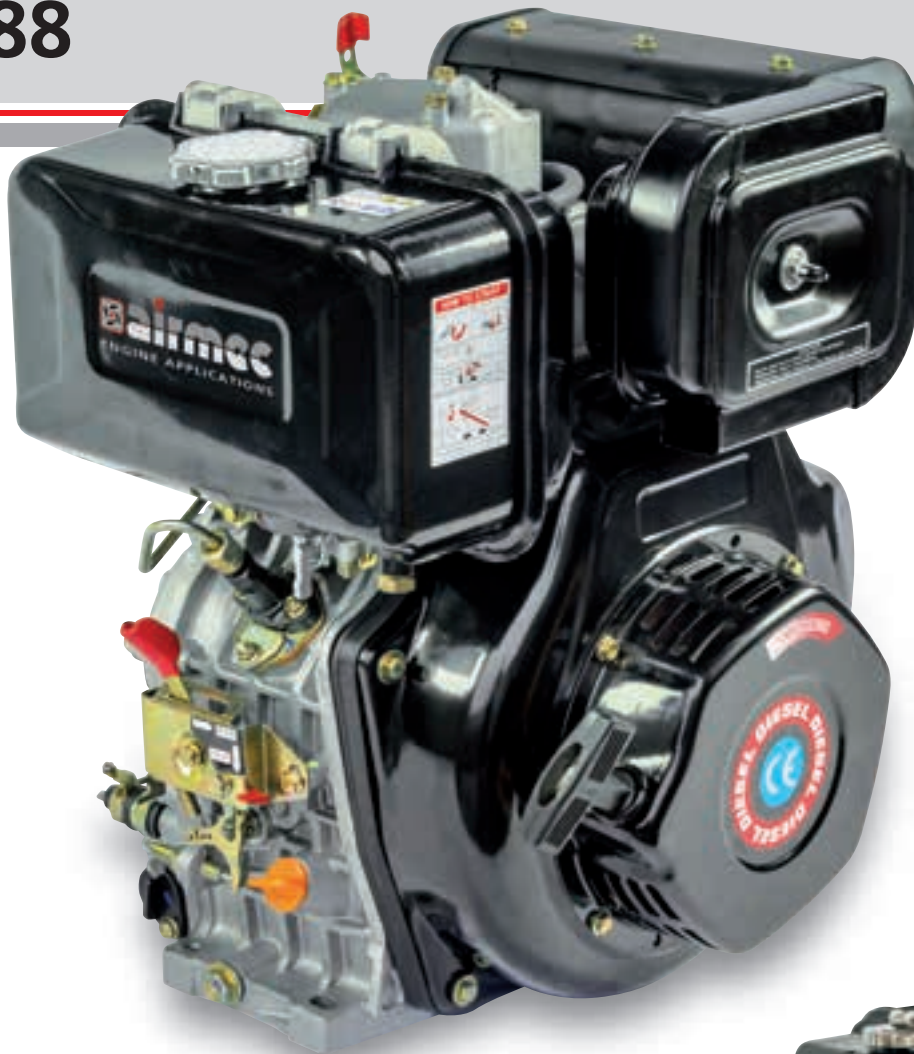

POWERED by
HAILIN[®]
diesel expert

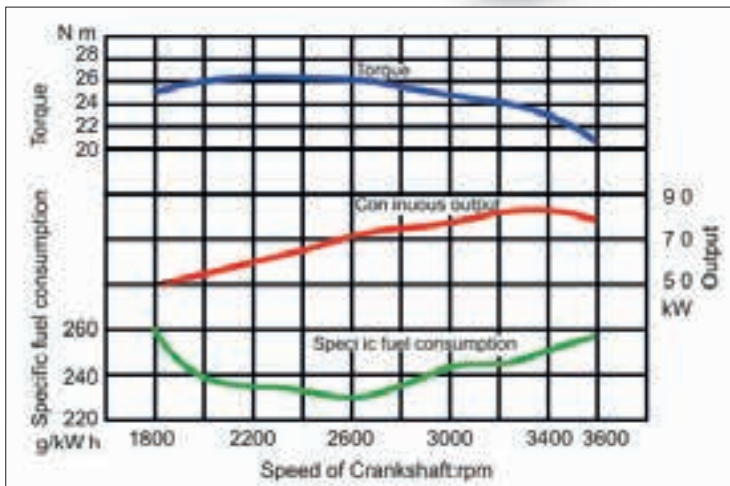

HL 188 FA G4-L

MOTORE - ENGINE

Carburante Fuel	Max. potenza resa Max. output	Potenza uso continuo Continuous output	Sistema avviamento Starting system	Cilindrata Displacement	Giri motore Engine speed
type	HP	HP	type	cc	r.p.m.
Diesel	12	11	manuale - elettrico recoil - electric	474	3600

Capacità serbatoio Tank capacity	Capacità serbatoio olio Oil tank capacity	Rumorosità Noise	Alesaggio corsa Bore Stroke	Dimensioni Dimensions	Peso a secco Dry weight
lt	lt	≤7m dB (A)	mm	mm	Kg
5,5	1,65	85	88 x 78	415 x 475 x 498	54

VERSIONE / VERSIONS



Albero conico D. 23 Type shaft

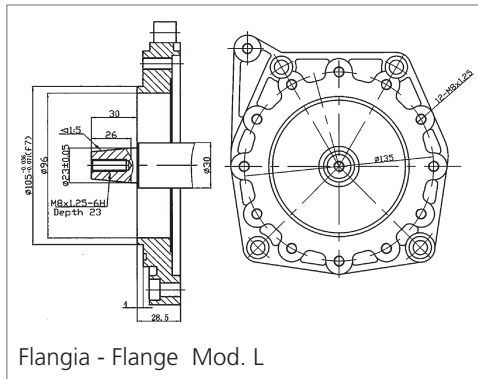

Flangia - Flange Mod. L

HL 188 FV-E G4 L

- Albero Conico D.23
- Avviamento Elettrico
- Filtro Aria bagno olio



Albero cilindrico D. 25.4
Cilindric shaft

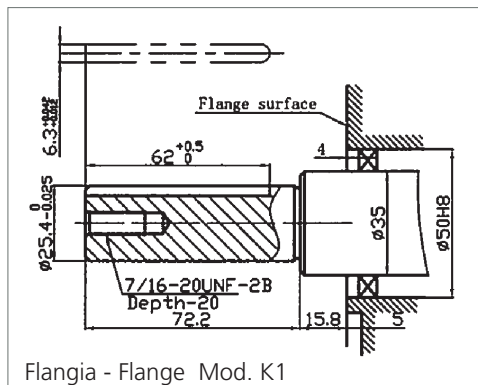

Flangia - Flange Mod. K1

HL 188 FV-E K1

- Albero Cilindrico D. 25.4
- Avviamento Elettrico
- Filtro Aria secco



Albero lungo generatore
Generator shaft

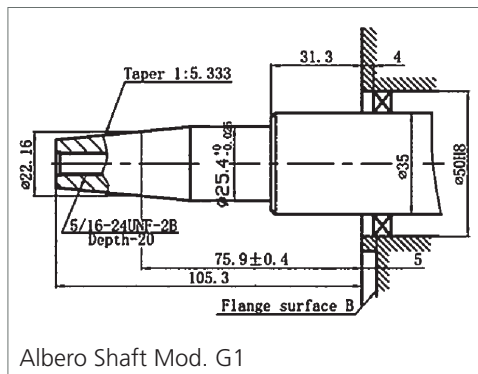

Albero Shaft Mod. G1

HL 188 FV-E G1

- Albero lungo generatore
- Avviamento Elettrico
- Filtro Aria secco